

KNUCKLE COUPLER INSTALLATION

- Remove Hook & Loop coupler.
- Clip tab "A" from end of tongue and file smooth.
- Attach USA knuckle coupler "B" with #4 screw (C) provided.

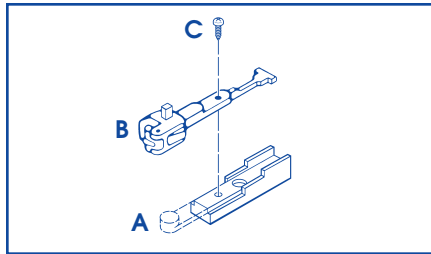

SERVICING

This Diesel locomotive is built with pride by USA Trains and is covered by a limited warranty. (See limited warranty terms). Please follow these instructions carefully before sending your locomotive for service:

1. Return locomotive in its original blue/red box with the proper foam inserts and then pack the original box in a proper shipping carton so it is well protected in shipment. The package must be fully insured and pre-paid. USA Trains is not responsible for damage or loss during shipment.
2. Include a note explaining the problem and servicing you need performed. Be sure to include your name, street address, (NO P.O. BOXES PLEASE) City, State, Country (if outside U.S.A) and zip code along with a daytime phone number including area code. If the locomotive service is not covered by warranty, a reasonable service fee will be charged. For any locomotives to be returned outside the continental U.S.A., please include \$25.00 U.S. currency to cover return postage. Any locomotives returned in the continental U.S.A. will be pre-paid by USA Trains.

3. Ship your item to:

USA TRAINS
662 CROSS STREET
MALDEN, MA. 02148

LIMITED ONE YEAR WARRANTY

This USA Trains locomotive is warranted for one year from the date of purchase against defects in material or workmanship. We will repair or replace (at our option) the defective part without charge for parts or labor within one year of the original date of purchase provided the warranty registration card has been received by USA Trains. This warranty does not cover items that have been abused or damaged by careless handling or improper operation such as a train derailment, modification or repair by non-factory technicians. Parts that "wear out" due to excessive use are also not covered under warranty. USA Trains reserves the right to determine "excessive use". Transportation costs incurred by the customer are not covered under this warranty.



EMD GP7 & GP9 DIESEL LOCOMOTIVE OWNERS MANUAL

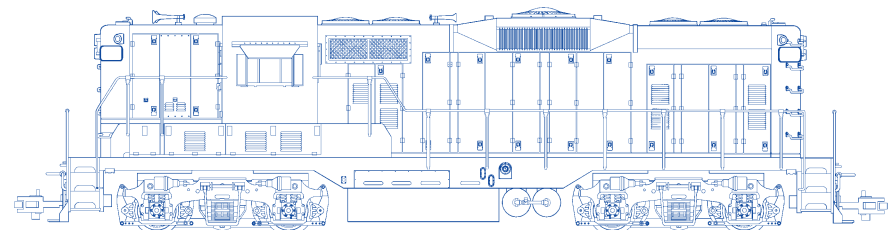
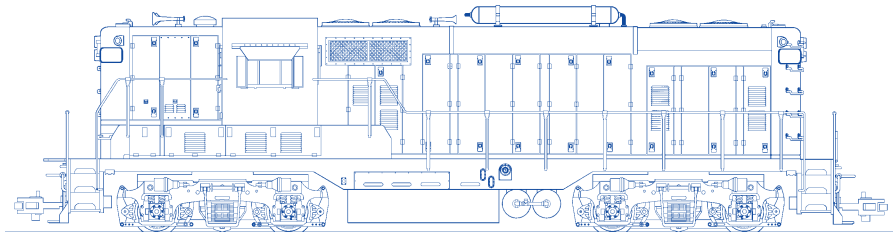

USA TRAINS
662 Cross Street
MALDEN, MA 02148, USA
www.usatrains.com



Dear Customer,

Congratulations on your purchase of this highly detailed replica of the electro-motive (EMD) GP-7.

The engineering and design staff at USA Trains has spent many hours reviewing original blueprints and developing a locomotive that looks authentic and will provide you with many hours of operating enjoyment all at a reasonable price. Over 400 parts make up this model - the level of detail found

in brass locomotives costing thousands of dollars for a fraction of the cost. This locomotive will enhance the appearance of any modelers railroad.

Please read the following instructions which will help you understand and operate the numerous features of this locomotive.

Happy Railroading
USA TRAINS

HISTORY OF THE EMD GP7 & GP9

General Motor's Electro-Motive division first introduced the GP (General Purpose) locomotive in 1949. As it's name indicates, the "Geep" was the locomotive the railroads were looking for - a versatile locomotive that could do anything. They were used by numerous railroads to pull every conceivable kind of train - way freight, branchline passenger, transfer drag, commuter, mainline freight and mainline passenger.

The Geep was designed as a simple, no frills locomotive and was priced below EMD's standard mainline freight offering. It was both reliable and functional and provided a better view of the railway. Access to engine from either side of the locomotive allowed for easy maintenance. Because of their usefulness and ease of maintenance, many "Geeps" were used into the 90's.

The accurate reproduction of this locomotive by USA Trains will allow the modeler to have his favorite railroad GP7 & GP9 running among the other locomotives on his/her railroad.

FEATURES

- Powerful dual-motored 8 wheel Power Trac drive train
- Dual operating fan driven smoke stacks "puff real smoke"
- Directional red/green marker lights
- Front & rear directional headlights
- Metal handrails
- Interior cab lighting
- Opening cab doors
- Detail cab interior with engineer and control panel with gauges
- Authentic detailing including diamond plate walkways, grating on steps, window shades, sliding windows and MU connectors
- Expert decoration reproducing authentic paint schemes of your favorite railroad

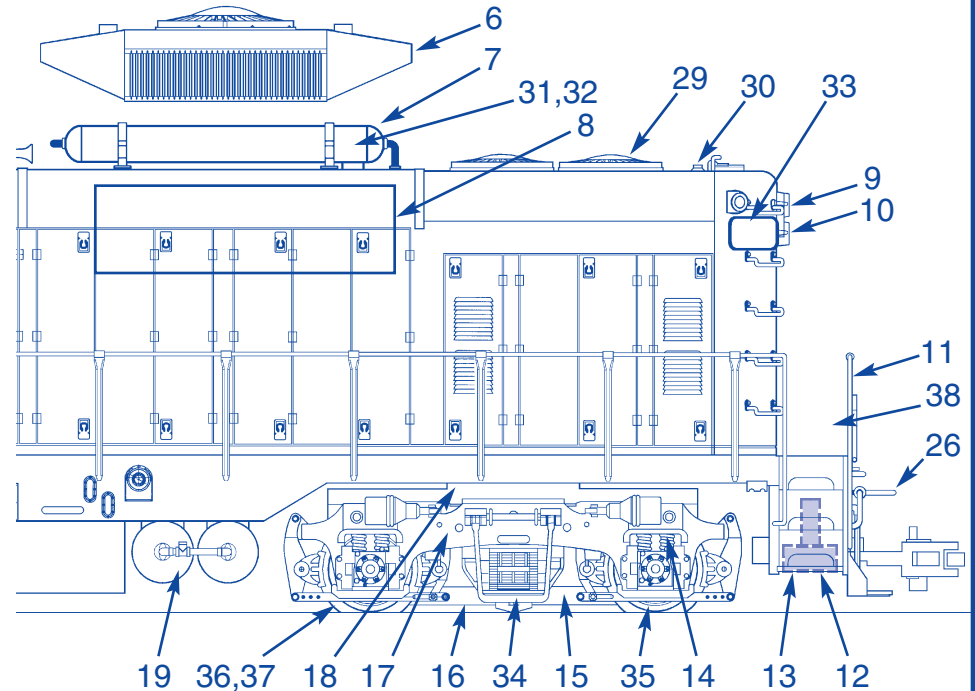

ITEM No.	PART No.	DESCRIPTION
25	R22-125	FOLD DOWN END STEP (2)
26	R22-126	COUPLER LIFT BAR WITH 4 HOLDERS (1)
27	R22-127	LIGHT BULB AND WIRE (Number Board)
28	R22-128	LIGHT BULB AND WIRE (Cab)
29	R22-129	ROOF FAN w/ ROTATING FAN BLADE (specify color)
30	R22-130	BRASS LIFT RINGS (14)
31	R22-131	SMOKE STACKS - PLASTIC (2)
32	R22-132	SMOKE STACKS - METAL (2)
33	R22-133	NUMBER PLATE - 1 END (specify number)
34	R22-134	STIRRUP FOR SIDE FRAME (4) (specify color)
35	R22-135	METAL WHEELS WITH GEARS (2)
36	R22-136	TRACTION WHEELS WITH GEARS (2) (for rubber tires)
37	R22-137	RUBBER TIRES (4)
38	R22-138	M.U. CONNECTOR (2)
39	R2021	SNOW PLOW
40	R22-476	SINGLE AIR HOSE (1)
	R50001	USA TRAINS SMOKE FLUID
	R50002	USA TRAINS CONDUCTIVE LUBRICANT
	1407-X004	MAIN CIRCUIT BOARD W/SWITCH PANEL (upgrade)
	1406-X004R1	SMOKE GENERATOR CIRCUIT BOARD (1) (fan driven)
	676-X005	FRONT HEADLIGHT CIRCUIT BOARD
	676-X008	REAR HEADLIGHT CIRCUIT BOARD

Please call our parts department for prices and availability or visit our web site www.usatrains.com • Phone: 781-322-6084 • Fax: 781-321-6459

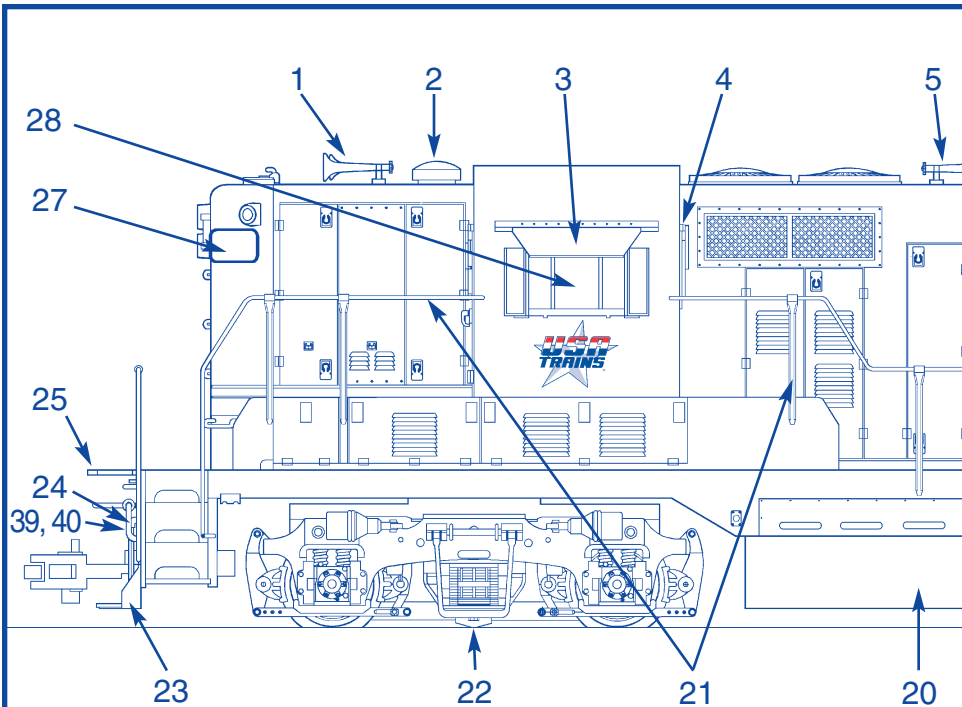

ASSEMBLY

Due to the high level of detail designed into the USA Trains GP7 & GP9, some simple assembly is required.

- (1) M.U. Connectors (2)**
Insert M.U. connector in frame as shown in diagram below. (both ends)
- (2) Fold Down Step (2)**
Insert step into step base assembly and insert into end of frame as shown in diagram below. (both ends)
- (3) Coupler Lift Bar Assembly (2)**
Insert 2 eye bolts onto each side of lift bar and inserted all 4 eyebolts onto frame as in diagram below. (both ends)
- (4) Air Hoses (6)**
Insert right and left air hoses (3) into frame and single air hose to right of coupler as shown in diagram below. (both ends)
- (5) Hand Rails - Sides and Ends (6)**
Insert side and end handrails into frame as shown in diagram below.
- (6) Smoke Stacks (6)**
Insert (2) plastic **or** (2) metal stacks into smoke stack holes as shown in diagram below.
NOTE: If running with smoke units on, **metal stacks** must be used due to heat of smoke unit. (See smoke unit operation next page).
- (7) Truck Sideframe Stirrups (4)**
Insert one truck side frame stirrup into each truck sideframe as shown on the diagram below. Proper installation will cover the top two side frame screws.
NOTE: Apply pressure to middle top slotted piece to ensure stirrup will stay on during operation.

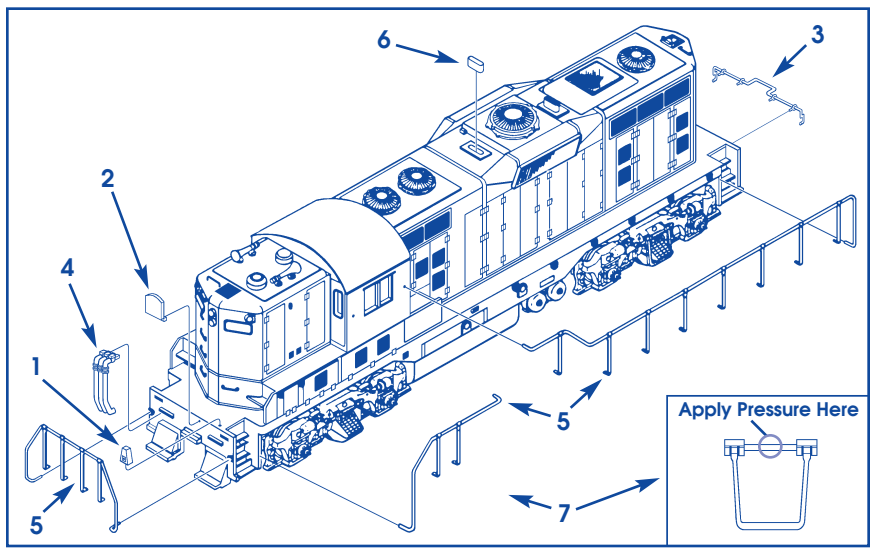

ITEM No.	PART No.	DESCRIPTION
1	R22-101	FRONT DIESEL HORN
2	R22-102	VENT PIPE (specify color)
3	R22-103	SUNSHADE (specify color)
4	R22-104	WINDSHIELD WIPERS (4)
5	R22-105	REAR DIESEL HORN
6	R22-106	DYNAMIC BRAKE (specify color)
7	R22-107	BRAKE CYLINDER (specify color)
8	R22-454	SMOKE UNIT (fan driven)
9	R22-109	LENS COVER (1)
10	R22-110	LIGHT BULB AND WIRE (Headlight)
11	R22-111	FRONT/REAR HANDRAILS (2) (specify color)
12	R22-112	COUPLER MOUNTING BLOCK & PIVOT (no coupler)
13	R22-113	COUPLER SPRING
14	R22-114	TRUCK SIDEFRAME SPRINGS (8)
15	R22-115	REPLACEMENT MOTOR TRUCK (1)
16	R22-116	REPLACEMENT MOTOR ONLY (1)
17	R22-117	TRUCK SIDEFRAME (2)
18	R22-118	TRUCK MOUNTING BLOCK (1)
19	R22-119	CYLINDERS (2)
20	R22-120	FUEL TANK (specify color)
21	R22-121	SIDE HANDRAILS (4) (specify color or undecorated)
22	R22-122	SLIDE SHOES & SPRINGS (4)
23	R22-123	END STEPS (specify color) (2)
24	R22-124	AIR HOSES (1 right, 1 left)

OPERATION

POWER REQUIREMENTS

The locomotive is designed to operate on direct current (DC) with outputs of 0-22 volts.

CONTROL SWITCHES

The locomotive contains four switches to operate the on/off motors, on/off smoke generator, on/off lights and on/off sound. The control switches are located on the underside of the locomotive, between the front motor truck and the fuel tank. (see diagram below)

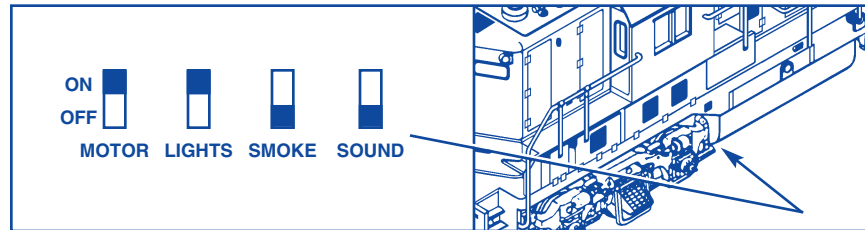

CAUTION! If the locomotive is going to be run for any period of time without smoke fluid, please position the smoke switch to the OFF position.

SMOKE GENERATOR

The locomotive contains two fan driven smoke units which produces "diesel exhaust" through the two stacks on the top side of the cab body. The smoke generators require the periodic addition of smoke fluid in order to operate properly. To add smoke, remove the stack from the top of the locomotive and add 25-30 drops of USA Trains smoke fluid (USA Trains part # R50001) into the smoke generator hole. Never overfill the smoke generator and promptly wipe up any excess smoke fluid that may have spilled onto any painted surfaces. Place both **metal** smoke stacks back on top of the locomotive, and begin operation. Smoke production will begin when the fluid becomes heated. It may take longer to generate the smoke if the unit is full. When the smoke chamber is empty the unit will shutdown automatically until more fluid is added. By following these directions the smoke generator will provide hours of enjoyment and enhance the realistic operation of your GP7 & GP9 locomotive.

CAUTION-USE ONLY THE METAL SMOKE STACKS PROVIDED WHEN OPERATING SMOKE UNIT.

CAUTION! Even though your locomotive is equipped with an automatic shut-off when the smoke generator runs out of fluid, we suggest you shut off the smoke switch on the underside of the locomotive to prevent accidental burning out of the smoke generator.

NOTE: It is not uncommon for the front stack to smoke more than the rear stack due to the draft created by movement of the locomotive.

MAINTAINING AND SERVICING YOUR GP7 & GP9

LUBRICATION

Your locomotive was lubricated at the factory and under normal operating conditions will not need to be lubricated during the first 50 hours of operation. The locomotive has three lubrication points. (See diagram below)

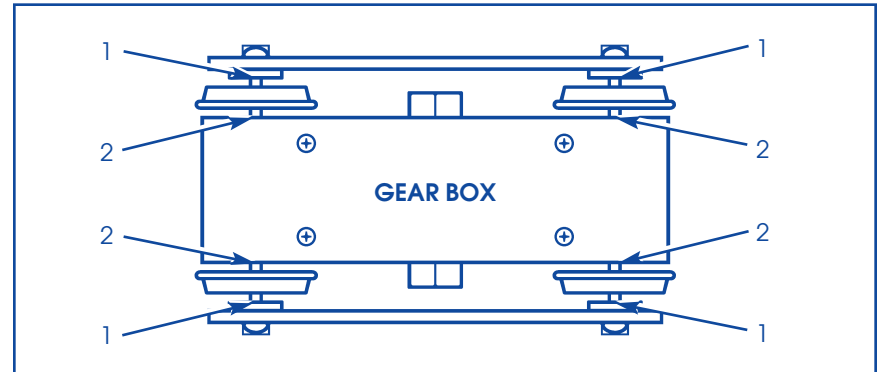

1. SIDEFRA M JOURNAL BOX: The axle ends fit into brass bushings which bring power into the locomotive. These brass bushings should periodically be cleaned out and lubricated with a small amount of USA Trains electrically conductive lubricant (USA Trains Part #R50002). Use only our conductive lubricant to avoid loss of electrical contact which could cause your locomotive to lose power or run erratically. The frequency of lubrication depends on your operating conditions.

2. AXLE LUBRICATION: Two drops of oil should be placed on all four contact points where the axle enters the gear box. An ultra light oil such as Hob-E-Lube (#HL653) is recommended.

3. GEAR BOX LUBRICATION: Under normal operating conditions, the gear box should not have to be lubricated. However, you may want to lubricate the gears after each 100 hours of operation by removing the six screws on the bottom of the gear box to expose the gears and applying moly grease by Hob-E-Lube to the gears on the axle only. Do not apply grease to any electrical contacts inside the gear box as you may hinder the electrical contacts required for smooth operation.

WHEEL/SLIDE SHOES

The GP7 & GP9 units are equipped with twelve electrical pickup points-six per motor truck. Each of these must be cleaned periodically to ensure proper electrical contact with the track which will ensure smooth operation of your locomotive. Clean all four wheels and the bottom surface of the slide shoes periodically to ensure good electrical contact with the track. A good indication that you need to clean these contacts is flickering lights, non-operation of the smoke unit, or a jerking motion of the locomotive.